

4

3

2

1

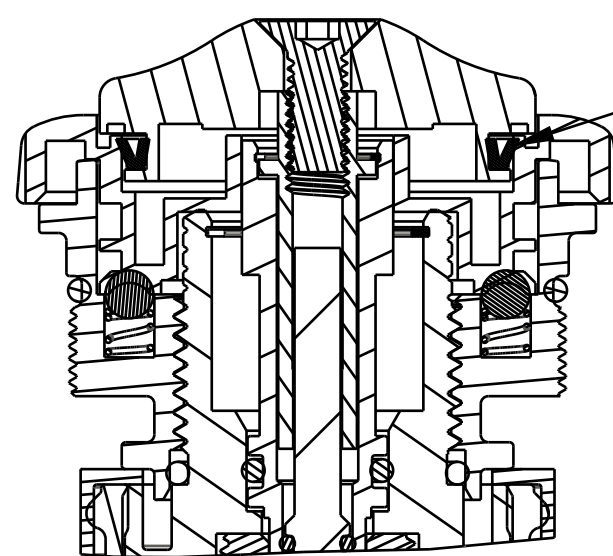

IMPORTANT:
NOTE ORIENTATION OF
U-CUP SEALS

241-00-020
Fastener, Custom: Cover, Nut 011 RC2

210-03-120
Knob, Rebound, 2011 36_40

241-00-022
Fastener, Custom: Nut, Bottom, 011 RC2

241-01-011
Fastener, Custom: Crush Washer, Plastic, 13mm

TORQUE:
5±1 IN.LB.

018-01-007
Socket Set Half Dog Point Screw [#8-32 X 0.250 TLG]

029-08-053
Seals: O-Ring [15mm ID x 1.5mm CS] Metric, N-70, Static

TORQUE:
65±5 IN.LB.

REFERENCE ONLY
(FOR INSTALLATION INTO FORK)

CARTRIDGE ASSY

GREASE:
THIN LAYER ON MATING
KNOB SURFACES

GREASE:
THIN LAYER ON MATING
OF SLICK HONEY

GREASE:
THIN LAYER

(010-01-000)

(039-00-005)

REFERENCE ONLY
(FOR INSTALLATION INTO FORK)

TORQUE:
220±5 IN.LB.

039-00-005
Spring: [0.125 TLG X 0.125 OD X 36.45 lbs/in]

GREASE:
THIN LAYER ON MATING
OF SLICK HONEY

010-01-000
Ball [Ø 0.1250] Steel

TORQUE:
11±3 FT.LB.

210-03-194
Knob, High Speed, Compression, 2014 RC2

036-01-074
Seal: U-Cup, Shore 70A, 2014 RC2, Low-Speed

210-03-193
Knob, Low Speed, Compression, 2014 RC2

019-01-060
Fastener, Standard (Metric): Screw [M4 X 10mm] Socket Flathead, Patchlock

FOX FOX Factory, Inc. Ph 831-768-1100
130 Hangar Way, Watsonville, CA 95076 USA Fax 831-768-9312

TITLE
2015 40
RC2 Cartridge, Complete

SIZE DWG. NO.
C

PLOT SCALE 0.50:1

SHEET 1 OF 1

PROPRIETARY
THIS DOCUMENT CONTAINS CONFIDENTIAL, PROPRIETARY INFORMATION
THAT IS FOX PROPERTY. DO NOT DISCLOSE TO OR DUPLICATE
FOR OTHERS EXCEPT AS AUTHORIZED BY FOX.

ProE ASSEM

4

3

2

1